

Intelligent Solar Charge Controller

User's Manual

Please read this manual carefully before you use this product.

Catalogue

1. Product Introduction.....	2
2. Installation.....	3
3. Operation.....	4
4. Common Breakdown and Disposal.....	10
5. Quality Assurance.....	11
6. Technical Data.....	13

1. Product Introduction

This controller is a kind of intelligent, multi-purpose solar charge and discharge controller. These serial products adopt customized LCD display screen, which makes the operation on the interface rather convenient. All the controlling parameters can be reset flexibly to satisfy your different needs. This controller has the following features:

- Visual LCD graphic symbol
- Automatic identification system voltage level
- Automatic temperature compensation
- Settable operating modes of loads
- Remote monitoring and control function (custom)
- Battery low voltage disconnection (LVD)
- Accumulated function of charge and discharge ampere hours
- Brief key operation
- Intelligent PWM charge mode
- Adjustable charge-discharge control parameters
- Overload & short circuit protection
- Battery reverse-discharge protection
- Battery reverses connection protection

2. Installation

Installation:

- ① Get ready the related tools and cables. We suggest you to choose the right cables to ensure the current density $< 4\text{mm}^2$ and this is good for reducing cable voltage drop. Recommendation: 20A、30A using 16mm^2 cable, 50A、60A using 25mm^2 cable. Check whether the installation place accords with the relative safety requirements. Please avoid installing and using the controller under the following conditions: damp, dusty places or places with flammable, explosive and corrosive gases
- ② Install the controller into a fixed vertical plane. Please refer to Chapter 5 for more detailed info about the spacing between the installing holes. In order to make the controller have a good thermal condition, please spare 10cm above & below the controller.
- ③ As shown on the right, connect the (1) Loads, (2) Battery and (3) Solar Panel with the controller in order. Pay attention to connect the loads, battery, solar panel and controller of same polarity.
- ④ Put the external thermal sensor into the interface of thermal-sensor on the left of the controller. The temperature sensor should be similar space with battery. (Otherwise, the controller will control the parameters of all wrong temperature compensation.)
- ⑤ If you have remote monitoring and control function, please insert one end of the included communication wire on the right of the controller (communication port), the other end to connect to the host computer.

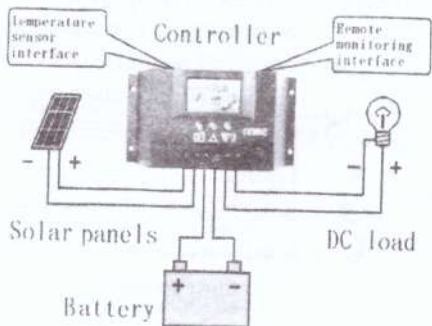















Demolition: To avoid the accident, please dismantle solar panels, battery and loads from the controller in order.

Attention: Connecting the battery reversed will not damage the controller, but will cause safety risk on your loads.



3. Operation

1. Description of LCD graphic symbol

-  : Stop supplying power for Loads
-  : Supplying power for Loads
the load circuit without current
-  : The load circuit with current
-  : Load
-  : Solar Panel
-  : Load sensor control
-  : Load timer control

-  : Stop the battery charging
-  : Bulk charging the battery
-  : Float charging the battery
-  : The system is working correctly
-  : The system is not working correctly
-  : Battery charge capacity display
-  : Battery

2. Description of button function:

-  : Interfaces circular toggling button. Use this button can realize the toggling circularly among the interfaces. The circular order is as follows: as shown as figure 1
-  : Adjustment of parameters plus buttons. Besides, under parameter view condition, press the button for over 5 seconds, and all the parameter will recover to the ex-work setting state.
-  : Adjustment of parameters minus button. Besides, at the main interface, this button can turn on or turn off the load.

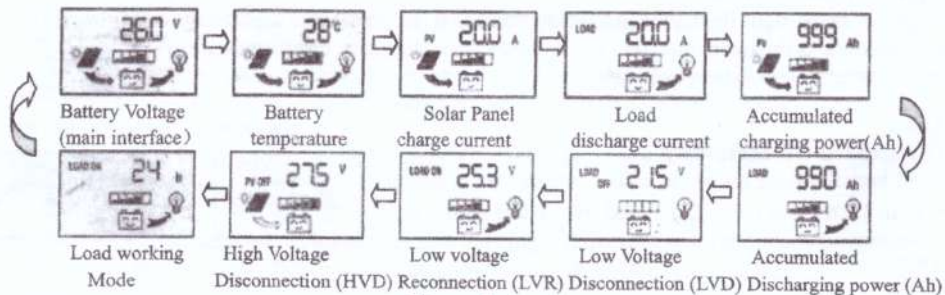





Figure 1

3. View and set the parameters

After the controller electrifies right, it will enter into the displaying interface of batter voltage. This interface is the main interface of the controller. Press the button  to go through the interface of the following parameters. If that interface could be reset, press the button  for long (>5seconds, and the number on the interface start to flicker), then it enter the setting interface of this parameter. After finishing the setting, press the button  for long to exit the setting interface, and the number stop flickering.

3.1 Battery Voltage review

As shown as the right figure, the displaying number is the present battery voltage. This interface is the main interface, and it shows the charging & discharge state, battery capacity and battery voltage.



3.2 The load On/Off controlling

At the batter voltage review interface, you can press button  to turn on or turn off the load, While this button does not have this function at other interface.



3.3 Environmental temperature review

As shown on the right, displays the ambient temperature of the controller, the value used for temperature compensation on LVD function. The sensor must be plug in before using the controller.



3.4 Review the generating current of solar panels

As shown as the right figure, the displaying number is the generating current of solar panels.



3.5 The load current review

As shown as the right figure, the displaying number is the load current.



3.6 Review and clearing the accumulative generating AH of solar panels

As shown as the right figure, the displaying number is the accumulative generating AH of solar panels.

At this interface, press the button  for long (>5seconds), and it can clear accumulative generating AH.

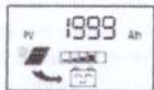

3.7 Review and clearing load accumulative discharging AH

As shown as the right figure, the displaying number is the accumulative discharging AH of loads.

At this interface, press the button  for long (>5seconds), and it can clear accumulative discharging AH.



3.8 Review and setting low voltage protection function

As shown as the right figure, the displaying number is the protection voltage. And if the battery voltage is lower than protection voltage, the controller will disconnect the load loop to prevent battery from over-discharging.

At this interface, press the button  for long (>5seconds), the number starts to flicker, and it means the controller enters into the interface of setting the protection voltage.

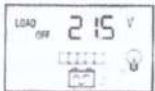

Use the key " \downarrow 、 $+$ " to adjust this parameter. After finishing setting, press the button ↵ for long (>5seconds) to exit this interface and the controller can store this setting number.

3.9 Review and setting recovering voltage for low voltage condition

As shown as the right figure, the displaying number is the recovery number. After the controller enters into low voltage protection state, when the battery voltage recovers to be higher than the recovery voltage, then the controller will reconnect the load loop automatically.



At this interface, press the button ↵ for long (>5seconds), the number starts to flicker, and it means the controller enters into the interface of setting the recovery voltage.



Use the key " \downarrow 、 $+$ " to adjust this parameter. After finishing setting, press the button ↵ for long (>5seconds) to exit this interface and the controller can store this setting number.

3.10 Review and setting the voltage of ceasing charging

As shown as the right figure, the displaying number is the voltage of ceasing charging. When the battery voltage reaches up to this voltage, the controller will disconnect the charging loop to prevent the battery from overcharging. After the battery voltage drops, the controller will reconnect the charging loop.



At this interface, press the button ↵ for long (>5seconds), the number starts to flicker, and it means the controller enters into the interface of setting the voltage of ceasing charging.

Use the key "  + to adjust this parameter. After finishing setting, press the button  for long (>5seconds) to exit this interface and the controller can store this setting number.



3.11 Review and setting the load mode

As shown as the right figure, it is the reviewing surface of the load mode. Different numbers represent different load mode.

24h—indicating normal mode, loads are under the condition of supplying power without breakdown.

1h~23h—indicating delayed mode of light control, loads start to supply power after dark and shun down after working for the delayed setting hours

0h—said light control mode, loads start to supply power after dark and stop working after drawn.

At this interface, press the button  for long (>5seconds), the number starts to flicker, and it means the controller enters into the interface of setting the load modes. Use the key "  + to adjust this parameter. After finishing setting, press the button  for long (>5seconds) to exit this interface and the controller can store this setting number.



4. Common Breakdown and Disposal

1. Low voltage protection and disposal:

If the screen shows as the right figure, it means the battery voltage is lower than the protection voltage. The controller enters into the low voltage protection state and the load loop disconnects. Use the solar panels or charger to charge for the battery. When battery voltage recovers to the protection voltage, the controller will recover to supply power for load and enter into the working state.

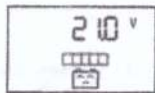

2. Overloading protection and disposal:

If the screen shows as the right figure, and the light flickers, it means the current of the load loop is 1.2 times of the rated current within 3 seconds, and the controller is at overload state. After removing some loads, the controller will supply power to the loads automatically within seconds, or you can press button "  to recover the power supply compulsively.

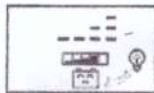

3. Short-circuit protection and disposal:

If the screen shows as the right figure, and the light flickers, it means there happens short-circuit in the load loop, and the controller is at short-circuit protection state. Please check whether the loads are damaged and whether the connecting cables are short-circuit. After eliminating the break down, press the button "  to recover the power supply for the loads.

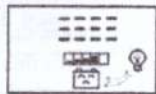

4. Breakdown and disposal of solar panels:

☞ Sign flickering means the controller do not detect the existence of solar panels. Please check whether the connection with solar panels are in good condition, and check whether the cables connecting the solar panels and controller are in open-circuit condition.

5. Load impulsion breakdown:

If the  flickers when you turn on the load, it means the starting impulsion current is more than twice of the rated working current. Please restart the controller for times.

5. Quality Assurance

1. Quality assurance should be carried out according to the flowing rules:

- The product is guaranteed of replacement, returning and repairing within 7days after sale.
- The product is guaranteed of replacement and repairing within 1 month after sale.
- The product is guaranteed of repairing within 12 months after sale.

2. If it is not possible to identify the using date of the controller, we would refer to the ex-work date, and prescribe 18 months as the warranty period. We need to charge beyond the warranty period. The controller

can be repaired for life no matter when and where you use it.

3. If the controller is damaged by the following causes, we need to charge even if it is in the guarantee period:

- Do not operate according to the user's manual.
- Use the controller under the condition which is beyond the using standard and technical requirements.
- Repair by yourself or reform by yourself.
- The inappropriate environmental condition can cause the breakdown and aging of the apparatus.
- Improper carrying or storage.
- Regarding to the service of replacement, returning and repairing, you need to retreat the product to our company, and we decide whether to replace or repair after we make clear who should be responsible.

6. Technical Data

Rated Voltage	12V/24V AUTO					48V				
Rated Current	20A	30A	40A	50A	60A	20A	30A	40A	50A	60A
Voltage of solar panels	≤50V					≤100V				
Float charging voltage	13.7V/27.4V					54.8V				
Low voltage protection	10.7V/21.4V					42.8V				
Low voltage recovery	12.6V/25.2V					50.4V				
Characteristic	No load loss:≤10mA; Loop voltage drop:≤170mV; Temperature compensation: -4mV/Cell/°C									
Working Environment	Operating Temperature: -20°C~60°C; Storage temperature: 30°C~70; Humidity requirements: ≤90%, no condensation									
Installation cable area	≤7# AWG (16mm ²)		>3# AWG (25mm ²)			≤7# AWG(16mm ²)		>3# AWG (25mm ²)		
Package size	209×110×63 mm		217×158×95mm			209×110×63 mm		217×158×95mm		
Weight	400g		620g			400g		620g		